



Application

- Can be used to transfer clean or slightly dirty water or other liquids similar to water in physical and chemical properties
- Suitable to be immersed in water for lifting water from the well or the pool, and draining water from the basement

Pump

- Stainless steel pump body
- Float switch ensures automatic cut-in and cut-out
- Max. liquid temperature: +35°C
- Max. immersion depth: 7 m
- Max. diameter of particle: 5 mm

Motor

- Motor with aluminum winding
- Built-in thermal protector
- Insulation class: F
- Protection class: IPX8

Identification Codes

XKS - 250 S

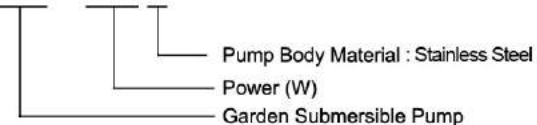

Hydraulic Performance Curves

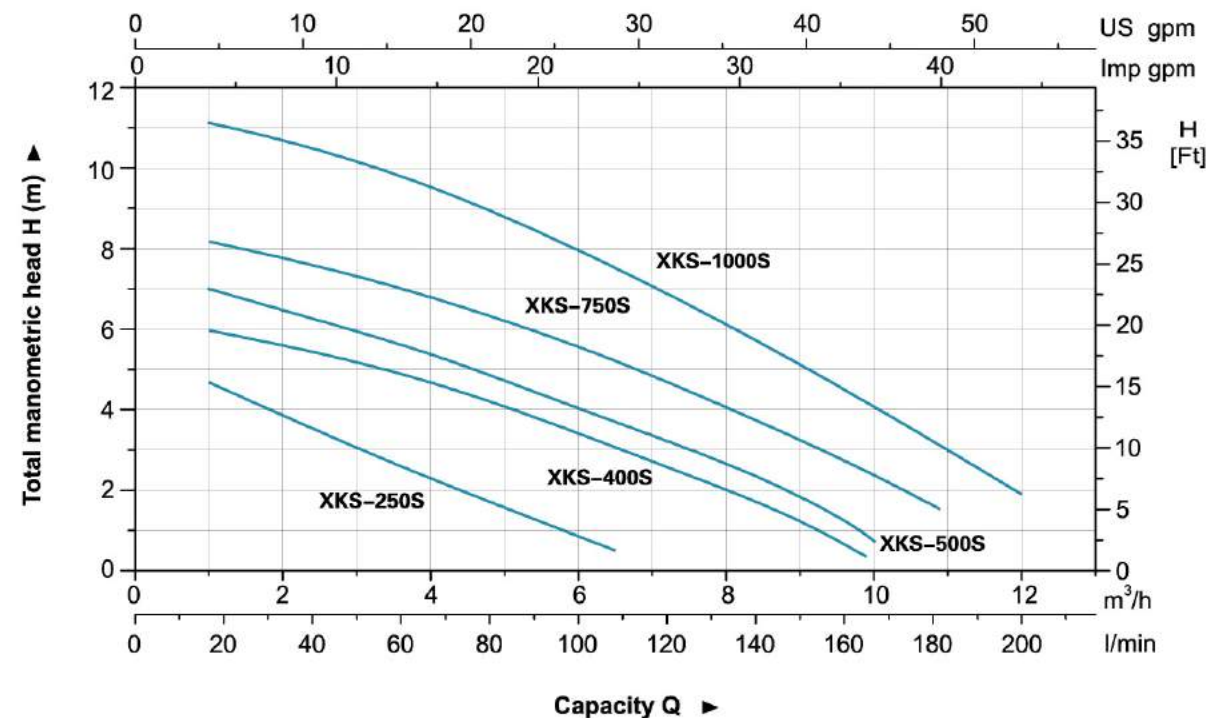

Technical Data

MODEL	POWER		Q (m³/h)	Q (l/min)	H (m)						
	W	HP			0	2	4	6	8	10	12
XKS-250S	250	0.3	H (m)	5.5	3.8	2.3	-	-	-	-	-
XKS-400S	400	0.5		6.3	5.5	4.5	3	2	-	-	
XKS-500S	500	0.7		7.5	6.5	5.3	4	2.5	-	-	
XKS-750S	750	1		8.5	7.8	6.8	5.5	4	2.3	-	
XKS-1000S	1000	1.3		11.5	10.6	9.5	8	6	4	1.9	

Materials Table

No.	Part	Material
1	Pump cover	AISI 304
2	Float switch	
3	Upper cover	PP
4	Capacitor	
5	Upper plate	ZL102
6	Pump base	AISI 304
7	Diffuser	PP
8	Impeller	PPO
9	Mechanical seal	Carbon/Ceramic
10	Pump support	ABS
11	Stator	
12	Ball bearing	
13	Rotor	
14	Connector	PP
15	Connector	PP

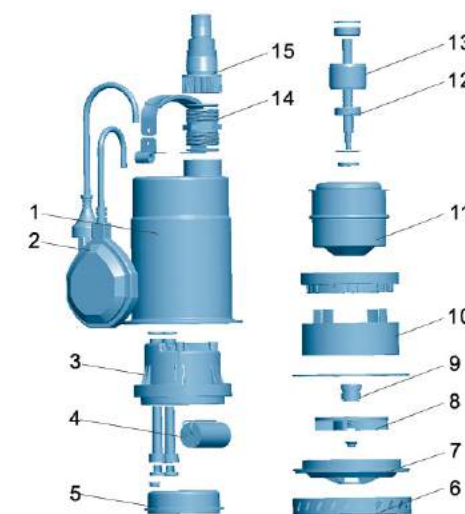

Package Information

Model	GW (Kgs)	L (mm)	W (mm)	H (mm)	Quantity (PCS/20 TEU)
XKS-250S	4.8	200	150	300	2632
XKS-400S	5.2	200	150	300	2632
XKS-500S	6.2	200	150	300	2632
XKS-750S	7.8	205	155	345	2160
XKS-1000S	7	205	155	345	2256

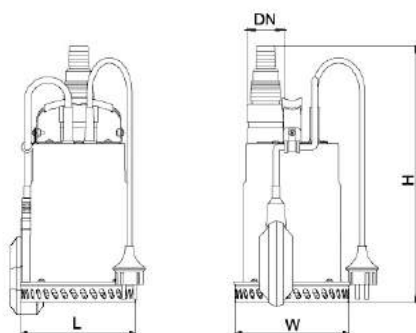

Dimension

Model	DN	L (mm)	W (mm)	H (mm)
XKS-250S	32	151	151	323
XKS-400S		151	151	323
XKS-500S		151	151	331
XKS-750S		151	151	347
XKS-1000S		151	151	326

Stainless Steel Garden Submersible Pump



Application

- Can be used to transfer clean or slightly dirty water or other liquids similar to water in physical and chemical properties
- Suitable to be immersed in water for lifting water from the well or the pool, and draining water from the basement

Pump

- Stainless steel pump body
- Float switch ensures automatic cut-in and cut-out
- Max. liquid temperature: +35°C
- Max. immersion depth: 7 m
- Max. diameter of particle: 35 mm

Motor

- Motor with aluminum winding
- Built-in thermal protector
- Insulation class: F
- Protection class: IPX8

Identification Codes

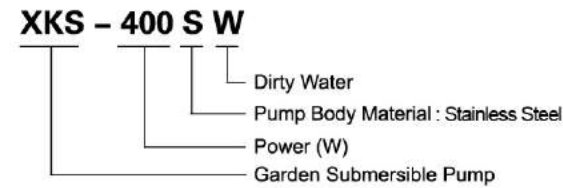

Technical Data

MODEL	POWER		Q (m ³ /h)	0	2	4	6	8	10	12
	W	HP								
XKS-400SW	400	0.5	H (m)	4.7	3.5	2.5	1.5	-	-	-
XKS-550SW	550	0.7		7	6.2	5.1	3.8	2.5	-	-
XKS-750SW	750	1		8.3	7.3	6.3	5.2	4.2	2.5	-
XKS-1000SW	1000	1.3		10.3	9.3	8.2	7	5.8	4.5	2.8
				0	33	67	100	133	167	200

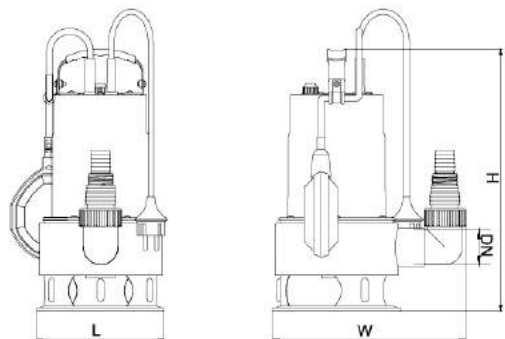

Dimension

Model	DN	L (mm)	W (mm)	H (mm)
XKS-400SW	40	165	248	340
XKS-550SW		165	248	340
XKS-750SW		165	248	351
XKS-1000SW		165	248	370

Hydraulic Performance Curves

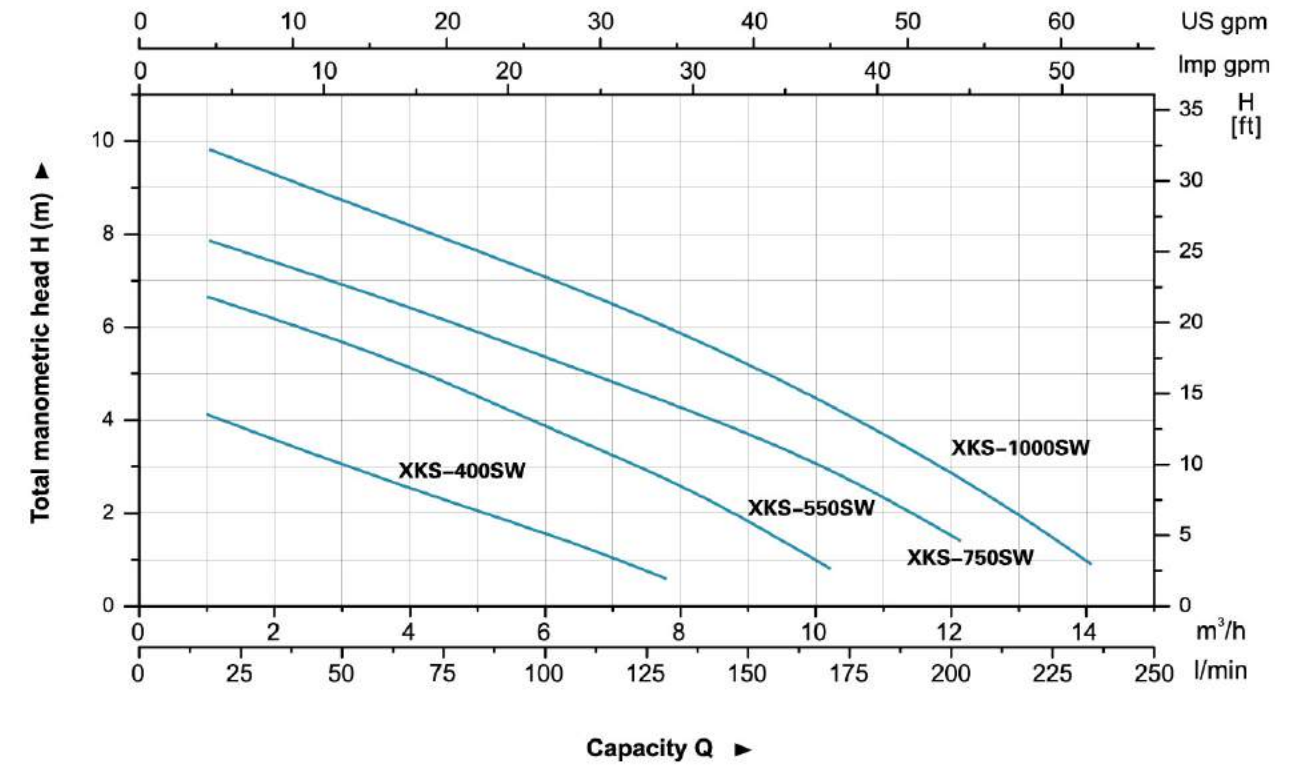

Materials Table

Pos.	Part	Material	Pos.	Part	Material
1	Handle	AISI 304	16	O-ring	NBR
2	Cable	Rubber	17	Canister	Stainless
3	Pump body	AISI 304	18	Lip seal	
4	Roof	PP	19	Retainer ring	PP
5	Jacket	NBR	20	Pump support	ABS
6	O-ring	NBR	21	Impeller	PA6
7	Pump body	AISI 304	22	Nut	AISI 304
8	Capacitor				
9	Float switch	PP			
10	Upper cover				
11	Stator				
12	Bearing				
13	Rotor				
14	Lip seal				
15	Bearing base	MPPO			

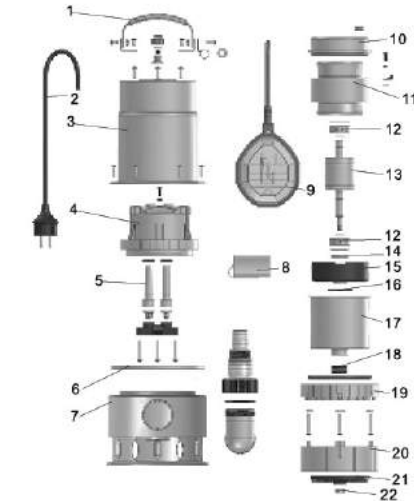

Package Information

Model	GW (Kgs)	L (mm)	W (mm)	H (mm)	Quantity (PCS/20 TEU)
XKS-400SW	5.7	210	165	350	1968
XKS-550SW	6.4	210	165	350	1968
XKS-750SW	7	210	165	350	1968
XKS-1000SW	8.6	215	170	355	1888

